

User Manual
netLINK NL 51N-DPL
Installation and Hardware Description



Hilscher Gesellschaft für Systemautomation mbH

www.hilscher.com

DOC100201UM02EN | Revision 2 | English | 2011-01 | Released | Public

Table of Contents

1	INTRODUCTION.....	4
1.1	About the User Manual.....	4
1.1.1	List of Revisions	4
1.1.2	Reference to Hardware	5
1.1.3	Reference to Firmware	5
1.1.4	Reference to SyCon Software	5
1.1.5	Conventions in this Manual	5
1.2	Contents of the Product DVD	6
1.2.1	Directory Structure of the DVD	6
1.2.2	Documentation Overview	7
1.3	Legal Notes	8
1.3.1	Copyright	8
1.3.2	Important Notes	8
1.3.3	Exclusion of Liability	9
1.3.4	Warranty	9
1.3.5	Export Regulations	10
1.3.6	Registered Trademarks	10
1.4	Licenses	10
2	SAFETY	11
2.1	General Note.....	11
2.2	Intended Use.....	11
2.3	Personnel Qualification	11
2.4	Commitment to read and understand the Manual.....	11
2.5	References Safety.....	11
2.6	Labeling of Safety Instructions	12
2.7	Safety Instructions.....	13
2.7.1	Damage by interrupting the Process	13
2.8	Property Damage Messages.....	14
2.8.1	Electrical Supply Voltage.....	14
2.8.2	Electrostatically sensitive Devices.....	14
3	DESCRIPTION AND REQUIREMENTS.....	15
3.1	Description	15
3.2	Requirements for Operation of the NL 51N-DPL	16
3.3	Configuration Requirements.....	16
4	DEVICE DRAWINGS AND CONNECTIONS	17
4.1	Dimensioned Drawing	17
4.2	Labels	17

4.3	Connections	18
4.3.1	X1 Power Supply	18
4.3.2	X2 Ethernet Interface	18
4.3.3	X3 PROFIBUS Interface	19
4.4	Schematic Diagram - Galvanic Isolation	20
5	COMMISSIONING	21
5.1	Warnings of Damage to Property	21
5.1.1	Electrostatically sensitive Devices	21
5.2	Mounting Instructions	21
5.3	Ethernet Connection	21
5.4	Configuration	22
5.4.1	Setting up the IP Address	22
5.4.2	Establishing Communication SYCON.net – netLINK 51N-DPL	22
5.4.3	Importing the GSD file	22
5.4.4	PROFIBUS Network Scan	23
5.4.5	Configuration download	23
5.4.6	Exporting the GSDML file	23
5.4.7	Configuring PROFINET Station Name/Multiple netLINKs	24
5.5	Start-up Behavior	25
5.6	Decommissioning	25
6	TROUBLESHOOTING	26
7	LEDS	27
8	TECHNICAL DATA	28
8.1	Device	28
8.2	Protocols	29
8.2.1	PROFINET IO Device	29
8.2.2	PROFIBUS-DP Master	30
9	LISTS	31
9.1	List of Figures	31
9.2	List of Tables	31
10	CONTACTS	32

1 Introduction

1.1 About the User Manual

This user manual contains a description for the netLINK NL 51N-DPL device using the netX 50 communication controller.

This user manual contains information for commissioning and use of the device.

1.1.1 List of Revisions

Index	Date	Chapter	Revisions
1	2010-08-13	all	Created
2	2011-01-31	4.1 8.1	Dimensions Dimensions, weight, power supply voltage

Table 1: List of Revisions

1.1.2 Reference to Hardware

Device	Revision
NL 51N-DPL	2

Table 2: Reference to Hardware

1.1.3 Reference to Firmware

Firmware	Revision
L51NPSDL.NXF	1.0.11.0

Table 3: Reference to Firmware

1.1.4 Reference to SyCon Software

Software	Revision
SyCon.net	1.300.x.x or higher

Table 4: Reference to Software

1.1.5 Conventions in this Manual

Operation instructions, a result of an operation step or notes are marked as follows:

Operation Instructions:

➤ <instruction>

Or

1. <instruction>

2. <instruction>

Results:

↪ <result>

Notes:



Important: <important note>



Note: <note>



<note, were to find further information>

1.2 Contents of the Product DVD

The product DVD for the netLINK NL 51N-DPL contains:

- Setup program for the configuration and diagnostics tool SYCON.net and Ethernet Device Setup Tool
- Documentation
- Firmware
- Device Description Files (GSD, GSDML, EDS, ...)

1.2.1 Directory Structure of the DVD

All manuals on this DVD are delivered in the Adobe Acrobat® Reader format (PDF).

Directory Name	Description
Adobe Flash Player	Adobe Flash Player installation program.
Documentation	Documentation in the Acrobat® Reader Format (PDF).
Driver	not needed for NL 51N-DPL
EDS	not needed for NL 51N-DPL
Examples	not needed for NL 51N-DPL
Firmware	Loadable Firmware.
fscommand	Files, used for installation.
Presentations	Product Presentations in PowerPoint pps format.
Software	Configuration and diagnostic program SYCON.net.
Tools	not needed for NL 51N-DPL
Video-Audio Tutorials	Video Tutorial/Podcast in AVI format of commissioning and configuration procedures. Contains a video in the folder "NL 51N-DPL – netLINK PROXY" illustrating a typical netLINK 51N-DPL commissioning procedure.

Table 5: Directory Structure of the DVD

1.2.2 Documentation Overview

The following documentation overview gives information, for which items you can find further information and in which manual.

Documentation for Users



Note: Further information:

All manuals listed in the overview below can be found in the Documentation directory on the delivered DVD in Adobe Acrobat® Reader format (PDF).

Manual	Contents	Document name
User Manual netLINK NL 51N-DPL	Installation and Hardware description of the netLINK NL 51N-DPL	netLINK NL 51N-DPL UM xx EN.pdf (this manual)
Operating Instruction Manual netGateway	Description of the configuration software SYCON.net for configuration of the NL 51N-DPL device: netGateway DTM for netTAP, netBRICK and netLINK; Configuration of Gateway- and Proxy Devices	netGateway_DTM_en.pdf
Operating Instruction Manual SYCON.net	Description of the configuration software SYCON.net	SYCONnet_netFrame_en.pdf
Operating Instruction Manual netDevice and net-Project	Configuration of field devices of various manufacturers	SYCONnet_netDevice_en.pdf
Operating Instruction Manual Ethernet Device Configuration	Assignment of IP-Address for the netLINK NL 51N-DPL	Ethernet Device Configuration OI xx EN.pdf

Table 6: Documentations for netLINK NL 51N-DPL for users

1.3 Legal Notes

1.3.1 Copyright

© Hilscher, 2010-2011, Hilscher Gesellschaft für Systemautomation mbH

All rights reserved.

The images, photographs and texts in the accompanying material (user manual, accompanying texts, documentation, etc.) are protected by German and international copyright law as well as international trade and protection provisions. You are not authorized to duplicate these in whole or in part using technical or mechanical methods (printing, photocopying or other methods), to manipulate or transfer using electronic systems without prior written consent. You are not permitted to make changes to copyright notices, markings, trademarks or ownership declarations. The included diagrams do not take the patent situation into account. The company names and product descriptions included in this document may be trademarks or brands of the respective owners and may be trademarked or patented. Any form of further use requires the explicit consent of the respective rights owner.

1.3.2 Important Notes

The user manual, accompanying texts and the documentation were created for the use of the products by qualified experts, however, errors cannot be ruled out. For this reason, no guarantee can be made and neither juristic responsibility for erroneous information nor any liability can be assumed. Descriptions, accompanying texts and documentation included in the user manual do not present a guarantee nor any information about proper use as stipulated in the contract or a warranted feature. It cannot be ruled out that the user manual, the accompanying texts and the documentation do not correspond exactly to the described features, standards or other data of the delivered product. No warranty or guarantee regarding the correctness or accuracy of the information is assumed.

We reserve the right to change our products and their specification as well as related user manuals, accompanying texts and documentation at all times and without advance notice, without obligation to report the change. Changes will be included in future manuals and do not constitute any obligations. There is no entitlement to revisions of delivered documents. The manual delivered with the product applies.

Hilscher Gesellschaft für Systemautomation mbH is not liable under any circumstances for direct, indirect, incidental or follow-on damage or loss of earnings resulting from the use of the information contained in this publication.

1.3.3 Exclusion of Liability

The software was produced and tested with utmost care by Hilscher Gesellschaft für Systemautomation mbH and is made available as is. No warranty can be assumed for the performance and flawlessness of the software for all usage conditions and cases and for the results produced when utilized by the user. Liability for any damages that may result from the use of the hardware or software or related documents, is limited to cases of intent or grossly negligent violation of significant contractual obligations. Indemnity claims for the violation of significant contractual obligations are limited to damages that are foreseeable and typical for this type of contract.

It is strictly prohibited to use the software in the following areas:

- for military purposes or in weapon systems;
- for the design, construction, maintenance or operation of nuclear facilities;
- in air traffic control systems, air traffic or air traffic communication systems;
- in life support systems;
- in systems in which failures in the software could lead to personal injury or injuries leading to death.

We inform you that the software was not developed for use in dangerous environments requiring fail-proof control mechanisms. Use of the software in such an environment occurs at your own risk. No liability is assumed for damages or losses due to unauthorized use.

1.3.4 Warranty

Although the hardware and software was developed with utmost care and tested intensively, Hilscher Gesellschaft für Systemautomation mbH does not guarantee its suitability for any purpose not confirmed in writing. It cannot be guaranteed that the hardware and software will meet your requirements, that the use of the software operates without interruption and that the software is free of errors. No guarantee is made regarding infringements, violations of patents, rights of ownership or the freedom from interference by third parties. No additional guarantees or assurances are made regarding marketability, freedom of defect of title, integration or usability for certain purposes unless they are required in accordance with the law and cannot be limited. Warranty claims are limited to the right to claim rectification.

1.3.5 Export Regulations

The delivered product (including the technical data) is subject to export or import laws as well as the associated regulations of different countries, in particular those of Germany and the USA. The software may not be exported to countries where this is prohibited by the United States Export Administration Act and its additional provisions. You are obligated to comply with the regulations at your personal responsibility. We wish to inform you that you may require permission from state authorities to export, re-export or import the product.

1.3.6 Registered Trademarks

Windows® 2000 / Windows® XP are registered trademarks of Microsoft Corporation.

Adobe-Acrobat® is a registered trademark of the Adobe Systems Incorporated.

S7, S7-300, S7-400 and MPI are registered trademarks of Siemens AG, Berlin and Munich.

PROFIBUS and PROFINET are registered trademarks of PROFIBUS International, Karlsruhe.

All other mentioned trademarks are property of their respective legal owners.

1.4 Licenses

The NL 51N-DPL device contains a license for the PROFIBUS-DP Master Link allowing the communication to a single PROFIBUS-DP Slave device.

2 Safety

2.1 General Note

The user manual, the accompanying texts and the documentation are written for the use of the products by educated personnel. When using the products, all safety instructions and all valid legal regulations have to be obeyed. Technical knowledge is presumed. The user has to assure that all legal regulations are obeyed.

2.2 Intended Use

The netLINK NL 51N-DPL may only be used as a part of a communication system as described in this manual.

The device may not be opened or be used when the housing has been removed.

2.3 Personnel Qualification

The netLINK NL 51N-DPL is used as a part of a system which must fulfill safety and accident precaution regulations depending on the respective conditions of use. The user of the system is exclusively responsible for the fulfillment of those regulations.

Therefore the system to which the netLINK NL 51N-DPL belongs may only be used by personnel who has been informed and educated about all relevant regulations.

2.4 Commitment to read and understand the Manual



Important! Read and understand all instructions in this manual before installation or use of your device to avoid injury.

2.5 References Safety

[1] EN 61340-5-1 and EN 61340-5-2 as well as IEC 61340-5-1 and IEC 61340-5-2

2.6 Labeling of Safety Instructions

The safety instructions are pinpointed particularly. The instructions are highlighted with a specific safety symbol, a warning triangle and a signal word according to the degree of endangerment. Inside the note the danger is exactly named. Instructions to a property damage message do not contain a warning triangle.



Symbol	Symbol (USA)	Sort of Warning or Principle
		Warning of Personal Injury
		Warning of damages by electrostatic discharge
		Principle: Mandatory read Manual

Table 7: Safety Symbols and Sort of Warning or Principle





Signal Word	Meaning	Signal Word (USA)	Meaning (USA)
DANGER	Indicates a direct hazard with high risk, which will have as consequence death or grievous bodily harm if it isn't avoided.		Indicates a Hazardous Situation Which, if not Avoided, will Result in Death or Serious Injury.
WARNING	Indicates a possible hazard with medium risk, which will have as consequence death or (grievous) bodily harm if it isn't avoided.		Indicates a Hazardous Situation Which, if not Avoided, could Result in Death or Serious Injury.
CAUTION	Indicates a minor hazard with medium risk, which could have as consequence simple battery if it isn't avoided.		Indicates a Hazardous Situation Which, if not Avoided, may Result in Minor or Moderate Injury.
NOTICE	Indicates a Property Damage Message.		Indicates a Property Damage Message.
Note	Indicates an important note in the manual.	Note	Indicates an Important Note in the Manual.

Table 8: Signal Words

In this document the safety instructions and property damage messages are designed according both to the international used safety conventions as well as to the ANSI standard, refer to reference safety [1].

2.7 Safety Instructions

To ensure your own personal safety and to avoid personal injury, you necessarily must read, understand and follow the following and all other safety instructions in this guide.

2.7.1 Damage by interrupting the Process

Damage can result process dependant, if the data communication in a process plant is interrupted. Clarify if damages can occur, before you remove the device from the process plant. Take care for security precautions to prevent damage of persons and property.



WARNING!

WARNING

Damage by interrupting the Process!

Take care for safe operation of the process plant before you remove the device from a process plant to prevent damage of persons and property.

2.8 Property Damage Messages

To avoid property damage respectively device destruction and to your system, you necessarily must read, understand and follow the following and all other property damage messages in this guide.

2.8.1 Electrical Supply Voltage

Use only 18..30 V for power supply to operate the device.



CAUTION!

NOTICE

Device Destruction!

Operation with more than 30 V power supply voltage will lead to destruction of the device.

2.8.2 Electrostatically sensitive Devices

Adhere to the necessary safety precautions for components that are vulnerable with electrostatic discharge.



NOTICE

NOTICE

Electrostatic Discharge

Protect the contacts of the D-Sub-plug from electrostatic discharge which may cause damage at the device.

Adhere to the necessary safety precautions for components that are vulnerable with electrostatic discharge (EN 61340-5-1 und EN 61340-5-2 as well as IEC 61340-5-1 und IEC 61340-5-2).

3 Description and Requirements

3.1 Description

The netLINK NL 51N-DPL device described in this user manual is an Ethernet Gateway based on netX technology.

netLINK PROXY integrates any PROFIBUS-DP Slave into a superordinate PROFINET network. Because of its structure as plug with a DSub housing, it can be plugged directly on to the PROFIBUS-DP interface of the PROFIBUS-DP-Slave and connected to the PROFINET network via the RJ45 connector.

On the side of PROFINET, the netLINK behaves just like a usual IO Device. The process data of the DP-Slave are assigned according to the guideline of the PI User Organization as a module in the respective PROFINET Slot/Subslot.

Powers the device with 24V= via the COMBICON connector.

Due to the short transmission way at the PROFIBUS it is not necessary to use a PROFIBUS termination resistor.

For the configuration of the NL 51N-DPL the configuration software "SYCON.net" and "Ethernet-Device Setup" has to be used.

The device is shipped with firmware. It has to be configured with the SYCON.net configuration software for its use case.

3.2 Requirements for Operation of the NL 51N-DPL

The following preconditions must be met in order to operate the NL 51N-DPL device successfully:

1. A suitable power supply (24 V) as described above is required.



NOTICE

Device Destruction!

- The reference potential of the power supply is galvanically connected with the reference potential of the PROFIBUS.
- The supplied voltage may not exceed 30 V DC, otherwise device damage may occur.

2. The configuration of the device must have been completed successfully. For this purpose, the system configurator SYCON.net is delivered with the device.

3.3 Configuration Requirements

The configuration software SYCON.net must be installed on a PC.

The requirements for the PC are:

- PC with 1 GHz processor or higher
- Windows® 2000 and Windows® XP
- Internet Explorer 5.5 or higher
- Free disk space: min. 400 MByte
- DVD ROM drive
- RAM: min. 512 MByte, recommended 1024 MByte
- Graphic resolution: min. 1024 x 768 pixel
- Keyboard and Mouse



Note: If the project file is saved and opened again or it is used on another PC, the system requirements need to match. Particularly the DTMs need to be installed on the used PC.



The installation of the SYCON.net configuration software is described in document *Software Installation - Gateway Solutions UM xx EN.pdf*.

4 Device Drawings and Connections

4.1 Dimensioned Drawing

Dimensions in mm.

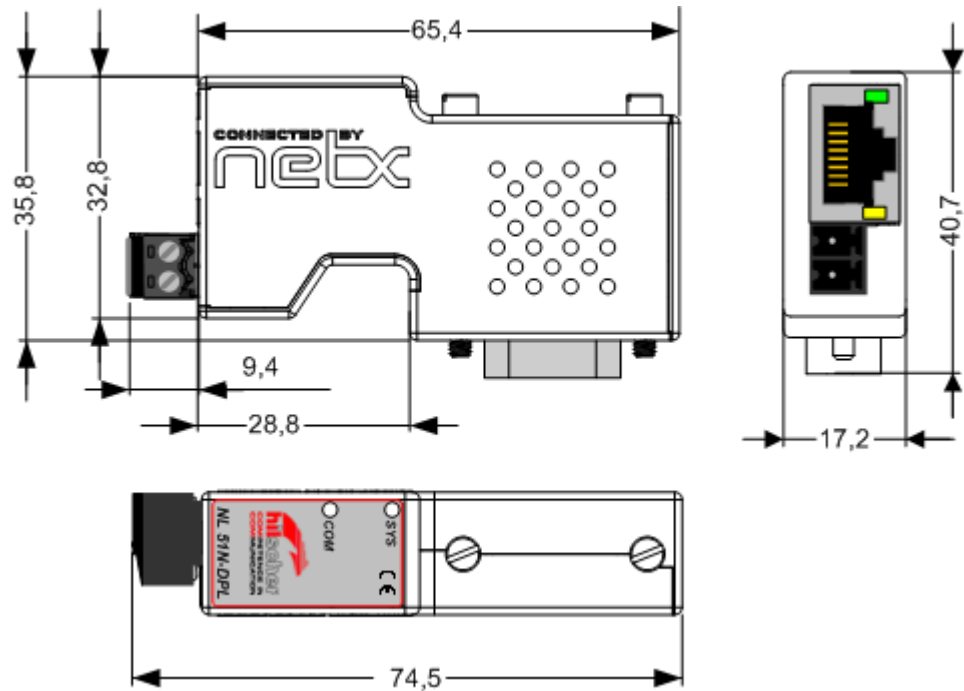

Figure 1: Dimensioned Drawing

4.2 Labels

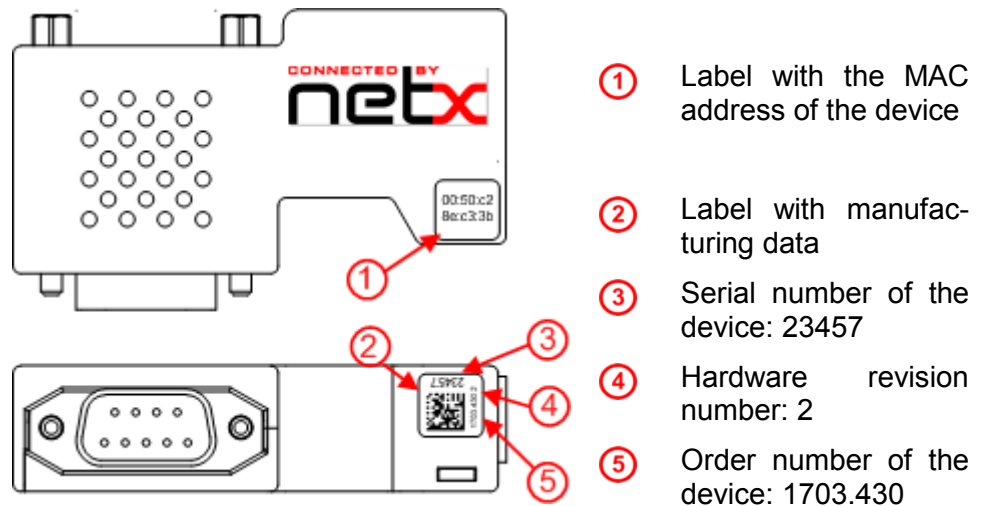

Figure 2: Labels

4.3 Connections



Figure 3: Connectors of the Device

4.3.1 X1 Power Supply

Power supply line pin assignment

Power supply line	Pin	Signal	Description
 Mini Combicon	1	0 V / GND	GND der Spannungsversorgung, 1 nf / 2000V gegen Schirm / Gehäuse.
	2	24 V	+24 V power supply

Table 9: Power supply line pin assignment

The plug for this connector is part of the delivery of the device.

4.3.2 X2 Ethernet Interface

Ethernet on RJ45 pin assignment

Ethernet	Pin	Signal	Description
 RJ45 socket, female	1	TX+	Transmit data positive
	2	TX-	Transmit data negative
	3	RX+	Receive data positive
	4	Term 1	Connected and terminated to PE via RC combination*
	5	Term 1	
	6	RX-	Receive data negative
	7	Term 2	Connected and terminated to PE via RC combination*
	8	Term 2	
			* Bob Smith Termination

Table 10: Ethernet RJ45 pin assignment

4.3.3 X3 PROFIBUS Interface

RS-485 Profibus pin assignment

PROFIBUS	Pin	Signal	Description
 <p>9 pin sub-D socket, male</p>	3	Rx/Tx +	Receive- / Transmit data positive.
	5	GND	Data ground, 1 nF / 2000V against PE
	8	Rx/Tx -	Receive- / Transmit data negative.
	Shield	PE	Metal shell on PE.

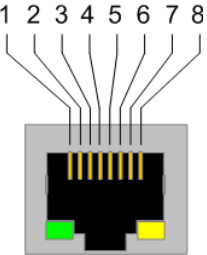
Table 11: PROFIBUS RS-485 pin assignment



Device Destruction!

- The reference potential of the power supply is galvanically connected with the reference potential of the PROFIBUS.
- If the power supply is not taken from the PROFIBUS DP Slave, but externally supplied, this external power supply must be potential free.

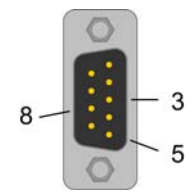
4.4 Schematic Diagram - Galvanic Isolation

The following schematic diagram illustrates the galvanic areas of separation.



Important: The PE connection of the device is done via shielding connectors of the PROFIBUS-DP plug and the shielding connector of the PROFINET IO plug via the metal housing of the Ethernet socket. The metalized outer part of the housing is on PE potential.

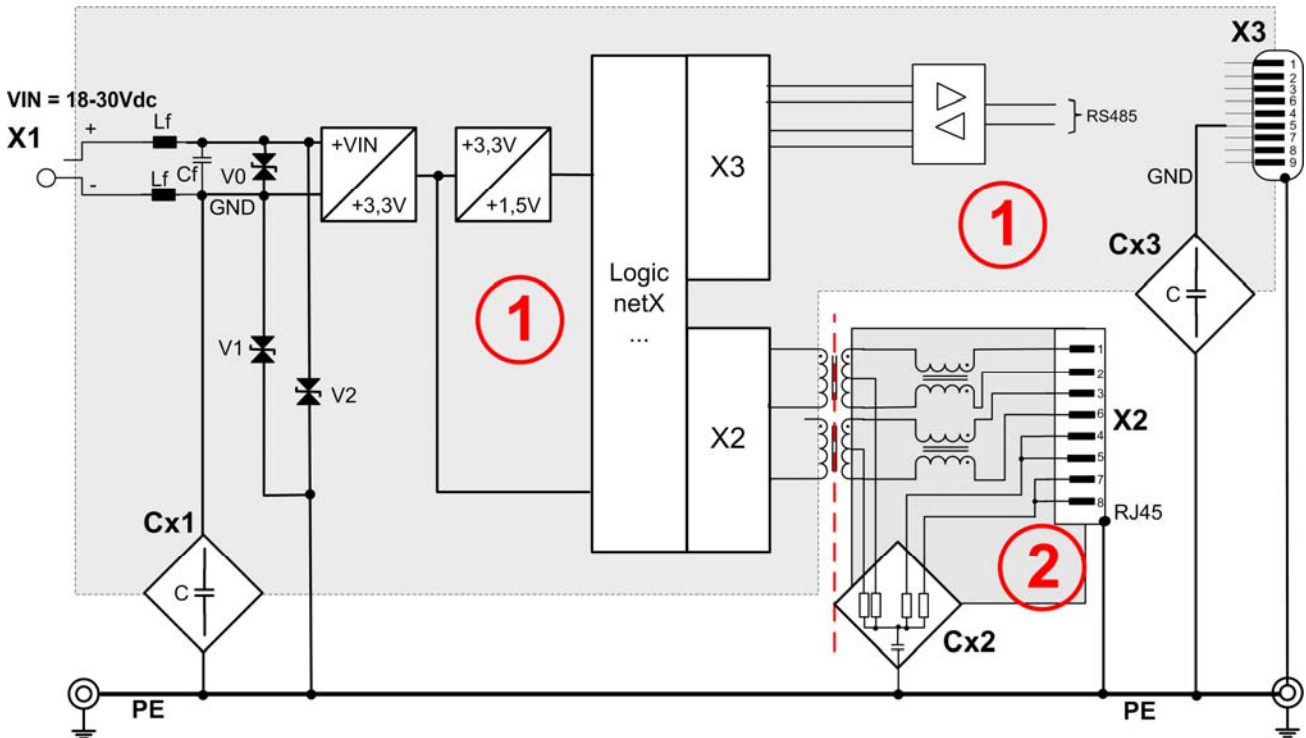

Figure 4: Galvanic Isolation

Area Connection	Protocol	galv. Isolation	Coupling	Coupling against PE potential	Functional earthing to PE
① X1	-	no	Cx1 ① V0, V1, V2	22 pF / 63 V $U_{BR} = 33 \dots 37 \text{ V}$	-
② X2	PROFINET IO	inductive	Cx2 ②	4 * 75 Ω, 1 nF / 2000 V	Directly via the metal connection of RJ 45 sockets
① X3	PROFIBUS DP	no	Cx3 ①	1 nF / 2000 V	Directly via the metal connection of D-Sub-socket

Table 12: Coupling NL 51N-DPL Devices

5 Commissioning

5.1 Warnings of Damage to Property

Take care of the following warnings of damage to Property during the installation of the netLINK NL 51N-DPL device.

5.1.1 Electrostatically sensitive Devices

Adhere to the necessary safety precautions for components that are vulnerable with electrostatic discharge.



NOTICE

Electrostatic Discharge

Protect the contacts of the D-Sub-plug from electrostatic discharge which may cause damage at the device.

Adhere to the necessary safety precautions for components that are vulnerable with electrostatic discharge (EN 61340-5-1 und EN 61340-5-2 as well as IEC 61340-5-1 und IEC 61340-5-2).

5.2 Mounting Instructions

The netLINK NL 51N-DPL is directly mounted on to the PROFIBUS-DP interface of the PROFIBUS-DP Slave device and securely screwed with the fixing screws.

Via the metal collar of the D-Sub plug, the housing of the netLINK NL 51N-DPL is connected to the shielding of the PROFIBUS Slave device. Thus the metal housing of the RJ45 socket is set to the same earthing potential.

5.3 Ethernet Connection

For NL 51N-DPL commissioning purpose and for the PROFINET operation the Ethernet Port X2 is used. The connection to the configuration PC may be realized with an ethernet patch cable directly or indirectly via the office or plant network. In case a configuration is needed during runtimes whilst PROFINET controller and network are already in use, it is mandatory to use a PROFINET switch in between the devices

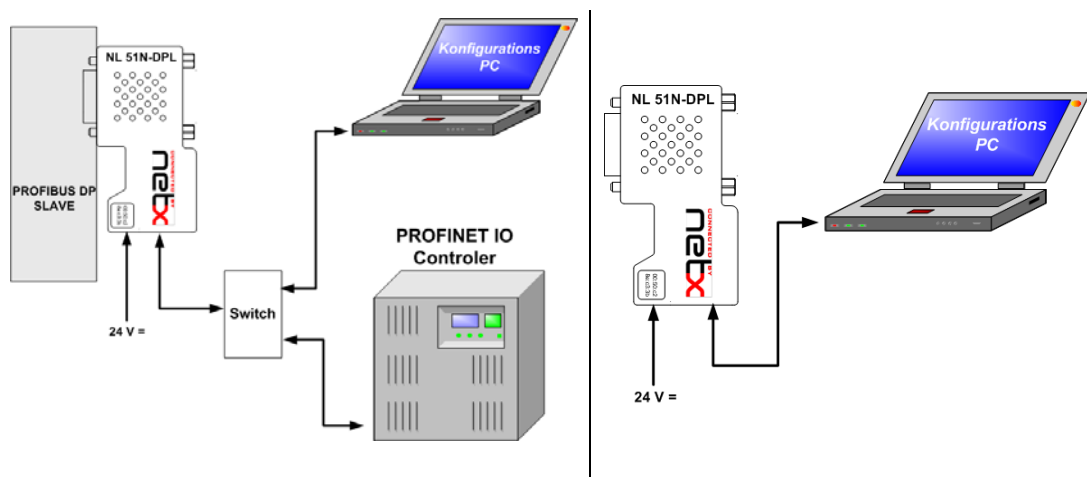

Figure 5: Possible Connections for Configuration

5.4 Configuration

By default the device is set up with IP address 0.0.0.0. For communication purpose the device needs a valid IP address first. The PROFINET controller allocates the IP address automatically during startup phase. For device configuration via the configuration PC the IP address has to be set manually.

5.4.1 Setting up the IP Address

Assigning an IP address is done with the software “Ethernet Device Setup”. It is installed during the setup of the SYCON.net configuration software. A network scan with this software will find Hilscher Device via ethernet broadcast messages abroad and independent of their IP address. Also devices with the IP address 0.0.0.0 will be found.



The procedure to assign an IP address is described in the user manual „Ethernet Device Configuration OI XX EN.pdf“ that you can find on the product DVD in the folder „Documentation\netLINK 51N-DPL\english\Ethernet Device Configuration“.



Note: Please consider that the intended IP address is not occupied already in your network and that it fits to the corresponding IP sub net your configuration PC belongs to. Normally the later used PROFINET IP address differs from the IP address that is used for configuration.



Note: In case the IP address is assigned with the Ethernet Device Setup tool using the “Netident” protocol, the address will not be saved permanently into the device. A power fail or a subsequent configuration download will reset the IP address back to the default value of 0.0.0.0. In case a reconfiguration is necessary, the IP address has to be assigned again as described above.

The assignment of the IP address enables the access of the SYCON.net configuration and its TCP/IP driver,

5.4.2 Establishing Communication SYCON.net – netLINK 51N-DPL



How to establish the communication between SYCON.net configuration software and the NL 51N-DPL device via the TCP/IP driver is described in the manual „netGateway_DTM_en.pdf“ in the section „Configuration of a NL 51N-DPL as Proxy“. You can find the manual on the product DVD in the folder „Documentation\SYCON.net\english“.

5.4.3 Importing the GSD file

Commissioning the NL 51N-DPL device requires the import of the connected PROFIBUS Slave into SYCON.net to make it public in the device catalogue.



Note: Ask the manufacturer of the PROFIBUS slave for the GSD file if it is not included in the delivery.



The procedure how to import the GSD file is described in the user manual „SYCONnet_netDevice_en.pdf“ that you can find on the product DVD in

the folder „Documentation\SYCON.net\english“.

5.4.4 PROFIBUS Network Scan

NL 51N-DPL is preconfigured with a PROFIBUS configuration of 1.5Mbaud. This enables an immediate PROFIBUS network scan via SYCON.net software. The scan identifies the connected PROFIBUS slave and prepares the configuration of NL 51N-DPL. The scan will only complete if the GSD file of the DP-Slave has been imported before.



The procedure to activate a PROFIBUS network scan is described in the user manual „PROFIBUS_Master_netX_DTM_en.pdf“ in the chapter „Automatic Network Scan“ that you can find on the product DVD in the folder „Documentation\SYCON.net\english\Protocol Specific Manuals“.

Of course you can configure the PROFIBUS slave manually. The procedure hereto is described in the same user manual.



Note: Today's PROFIBUS Slave protocol chips are detecting the baudrate automatically. This ensures that nearly any PROFIBUS slave is reliable scanned at 1.5Mbaud. Just in case the connected PROFIBUS slave does not support this baudrate, you have to configure the correct baudrate in the PROFIBUS master parameter dialog of SYCON.net and download it to NL 51N-DPL.

5.4.5 Configuration download

After the preparation of NL 51N-DPL's configuration a download loads all parameters into the device remanently. The device will start immediately with the communication to the PROFIBUS slave. The LED COM illuminates green. After the download the device will reset the IP address back to 0.0.0.0. It is then ready to receive its IP address from the PROFINET controller.



The procedure for downloading the configuration is described in the user manual „SYCONnet_netDevice_en.pdf“ in the chapter „Download“ that you can find on the product DVD in the folder „Documentation\SYCON.net\english“.

5.4.6 Exporting the GSDML file

For the operation of the NL 51N-DPL device at a PROFINET controller a GSDML file is needed. Because of the dynamic PROFIBUS configuration of NL 51N-DPL and its immediate influence on the GSDML file, SYCON.net support the online generation of this file. Export the GSDML file after having finished the device's configuration and configure your PROFINET controller with it.



The procedure how to export a GSDML file is described in the manual „netGateway_DTM_en.pdf“ that you can find on the product DVD in the folder „Documentation\SYCON.net\english“.

5.4.7 Configuring PROFINET Station Name/Multiple netLINKs

The PROFINET default station name the NL 51N-DPL device identifies itself is "nl51ndpl". In case multiple netLINK devices of the type and configuration are operated in a single PROFINET segment each of them must get a unique PROFINET station name to enable a clear identification for a PROFINET controller.

The first option to modify the station name is using SYCON.net configuration software. The name can be modified in the "PROFINET Device" parameter dialog. A subsequent download to the device would change the station name accordingly and the export of the GSDML file then would provide the new name to the PROFINET controller software.

The second option is the preferred one since it is not recommended to generate multiple GSDML files with SYCON.net for a device with the same configuration that just needs a different name. PROFINET features changing PROFINET station names or IP addresses of PROFINET device online via ethernet using the so-called DCP protocol after their initial configuration.

The netLINK PROFINET station name or its IP address can be modified and set permanently online at any time using the "Ethernet Device Setup" tool and the DCP protocol feature.



The procedure of how to set station name and IP address via the DCP protocol is described in the user manual „Ethernet Device Configuration OI 02 XX.pdf“ that you can find on the product DVD in the folder „Documentation\netLINK 51N-DPL\english\Ethernet Device Configuration“.

5.5 Start-up Behavior

After a configuration download or return of power it will take approximately 2 s until the device is operational. The communication to the PROFIBUS slave will be initiated immediately once the device is configured for PROFIBUS. This PROFIBUS communication can never be interrupted.

Per default the device uses the IP address 0.0.0.0 on ethernet. In case the IP address has been modified with SYCON.net or “Ethernet Device Setup” Tool or the device has been operated on PROFINET already this IP address may vary.

In case there was a configuration inconsistency detected during a configuration download or a download has been interrupted the device falls back to default IP address 0.0.0.0. In this state the device can be identified again with the “Ethernet Device Setup” tool and assigned a valid IP address. Afterwards you can use SYCON.net software as usual to configure the device.

5.6 Decommissioning

Damage can result process dependant, if the data communication in a process plant is interrupted. Clarify if damages can occur, before you remove the device from the process plant. Take care for security precautions to prevent damage of persons and property.



WARNING!

WARNING

Take care for safe operation of the process plant before you remove the device from a process plant to prevent damage of persons and property.

6 Troubleshooting

There are two levels of error analysis:

- The analysis of the status information of the LEDs at the device, see section LEDs at page 27
- The analysis of the Ethernet interface of the device with a PC running the software SYCON.net.
This kind of analysis can only be done if the PC running the software SYCON.net can be looped in via a switch into the communication path of the PROFINET IO bus system.



More information concerning the online diagnosis in SYCON.net can be found in the documentation directory of the Product CD in file „netGateway_DTM_de“.

7 LEDs

The subsequent table describes the meaning of the system LED.

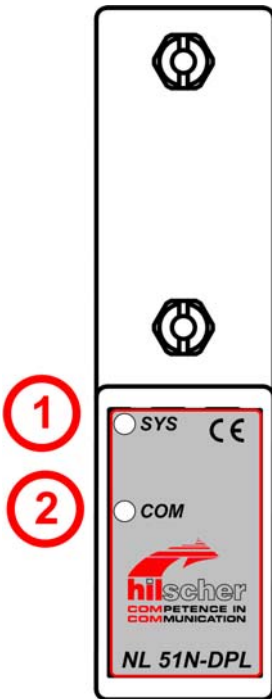





LED	Color	State	Meaning
SYS Number in the drawing ①	Duo LED yellow/green		
	 (green)	On	Operating System running
	 (yellow)	On	This state may occur just for a short time. In case the LED is illuminating yellow permanently the device may have a hardware malfunction.
	 (yellow/green)	Flashing yellow/green	The bootloader is active, and loads the firmware from the FLASH memory. In case this state remains active permanently the device has to be returned to Hilscher for repair.
		Off	Power supply for the device is missing or hardware defect.

Table 13: System LED

The subsequent table describes the meaning of the LEDs of the PROFIBUS DP Master protocol.





LED	Color	State	Meaning
COM ②	Duo LED red/green		
	 (green)	Flashing acyclic	No configuration or stack error
	 (green)	Flashing cyclic	Profibus is configured, but bus communication is not yet released from the application
	 (green)	On	Communication to the Slave is established
	 (red)	Flashing cyclic	Communication to at least one Slave is disconnected
	 (red)	On	Communication to one/all Slaves is disconnected

Table 14: LEDs PROFIBUS DP Master

The subsequent table describes the meaning of the LEDs for the Real-Time Ethernet device.



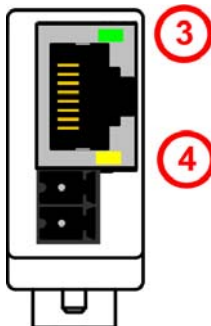

LED	Color	State	Meaning
LINK RJ45 ③	LED green		
	 (green)	On	A connection to the Ethernet exists
	-	Off	The device has no connection to the Ethernet
RX/TX RJ45 ④	LED yellow		
	 (yellow)	Flashing	The device sends/receives Ethernet frames

Table 15: LEDs PROFINET IO-RT-Device

8 Technical Data

8.1 Device

NL 51N-DPL	Parameter	Value
Communication controller	Type	netX 50
Memory	RAM	8 MB SDRAM
	FLASH	4 MB serial Flash, with bootloader, firmware and configuration
PROFIBUS Interface	Transmission rate	9,6 kBit/s up to 12 MBit/s
	Interface Type	RS-485 (connected to power supply potential)
	Connector	DSub-Plug 9-pin
	Automatic Baud rate detection	supported
Ethernet communication	Data transport	TCP/IP
	Number of connections	max. 16 TCP connections at a time
	PROFINET IO Controller connections	1
Ethernet Interface	Transmission rate	10/100 MBit/s
	Interface Type	100 BASE-TX, isolated
	Connector	RJ45- female
	Auto-Negotiation	supported
	Auto-Crossover	supported
Display	LED Display	SYS System Status COM Communication Status ACT Ethernet Activity Status LNK Ethernet Link Status
Power supply	Voltage	9 ... 30 V DC
	Current at 18 V	typ. 80 mA
	Current at 24 V	typ. 70 mA
	Current at 30 V	typ. 53 mA
	Connector	Mini-COMBICON -Socket 3,81 mm 2-pin
Emission		CISPR 11 Class A
Immunity		EN 61131-2: 2003
Environmental conditions	Temperature rang	0 ... + 50 °C
	Humidity	0 ... 85 % (no condensation allowed)
Device	Dimensions (L x W x H)	74,5 x 40,7 x 17,2 mm
	Weight	appr.35 g
	Mounting / Installation	onto PROFIBUS Socket
	Protection Class	IP 20
	CE Sign	Yes
Configuration	Software	SYCON.net
	Software	Ethernet-Device Setup

Table 16: Technical Data NL 51N-DPL

8.2 Protocols

8.2.1 PROFINET IO Device

Parameter	Description
Maximum number of cyclic input data	244 bytes (Maximum number of a PROFIBUS-DP Slave)
Maximum number of cyclic output data	244 bytes (Maximum number of a PROFIBUS-DP Slave)
Alarm Types	Process Alarm, Diagnostic Alarm, Return of SubModule Alarm
Supported protocols	RTC – Real Time Cyclic Protocol, Class 1 and 2 (unsynchronized) RTA – Real Time Acyclic Protocol DCP – Discovery and configuration Protocol CL-RPC – Connectionless Remote Procedure Call LLDP – Link Layer Discovery Protocol SNMP – Simple Network Management Protocol
Used Protocols (subset)	UDP, IP, ARP, ICMP (Ping)
Topology recognition	LLDP, SNMP V1, MIB2, physical device
VLAN- and priority tagging	yes
Context Management by CL-RPC	Supported
Minimum cycle time	1 ms
Baud rate	100 MBit/s
Data transport layer	Ethernet II, IEEE 802.3
Limitations	RT over UDP not supported Acyclic communication not supported Multicast communication not supported DHCP is not supported IRT is not supported: neither synchronized RT Class 2 'flex' nor RT Class 3 'top' FastStartUp not supported Media Redundancy (MRP, MRRT) is not supported The amount of configured IO-data influences the minimum cycle time that can be reached. Supervisor-AR is not supported Only 1 Input-CR and 1 Output-CR are supported
Reference to firmware/stack version	V3.4.x.x

Table 17: Technical Data PROFINET IO RT IRT Device Protocol

8.2.2 PROFIBUS-DP Master

Parameter	Description
Maximum number of PROFIBUS-DP slaves	1 (to one slave only)
Maximum number of cyclic input data	244 bytes
Maximum number of cyclic output data	244 bytes
Configuration data	Max. 244 bytes
Parameterization data	7 bytes standard parameters Max. 237 bytes application specific parameters
Baud rate	9,6 kBits/s, 19,2 kBits/s, 31,25 kBits/s, 45,45 kBits/s 93,75 kBits/s, 187,5 kBits/s, 500 kBits/s, 1, 5 MBits/s, 3 MBits/s, 6 MBits/s, 12 MBit/s Auto baudrate detection is not supported
Data transport layer	PROFIBUS FDL
Limitations	DP V1 services class 1 and 2 are not supported DP V2 services are not implemented
Reference to firmware/stack version	V2.2.x.x

Table 18: Technical Data PROFIBUS-DP Master Link Protocol

9 Lists

9.1 List of Figures

Figure 1: Dimensioned Drawing	17
Figure 2: Labels	17
Figure 3: Connectors of the Device	18
Figure 4: Galvanic Isolation	20
Figure 5: Possible Connections for Configuration	21

9.2 List of Tables

Table 1: List of Revisions	4
Table 2: Reference to Hardware	5
Table 3: Reference to Firmware	5
Table 4: Reference to Software	5
Table 5: Directory Structure of the DVD	6
Table 6: Documentations for netLINK NL 51N-DPL for users	7
Table 7: Safety Symbols and Sort of Warning or Principle	12
Table 8: Signal Words	12
Table 9: Power supply line pin assignment	18
Table 10: Ethernet RJ45 pin assignment	18
Table 11: PROFIBUS RS-485 pin assignment	19
Table 12: Coupling NL 51N-DPL Devices	20
Table 13: System LED	27
Table 14: LEDs PROFIBUS DP Master	27
Table 15: LEDs PROFINET IO-RT-Device	27
Table 16: Technical Data NL 51N-DPL	28
Table 17: Technical Data PROFINET IO RT IRT Device Protocol	29
Table 18: Technical Data PROFIBUS-DP Master Link Protocol	30

10 Contacts

Headquarters

Germany

Hilscher Gesellschaft für
Systemautomation mbH
Rheinstrasse 15
65795 Hattersheim
Phone: +49 (0) 6190 9907-0
Fax: +49 (0) 6190 9907-50
E-Mail: info@hilscher.com

Support

Phone: +49 (0) 6190 9907-99
E-Mail: de.support@hilscher.com

Subsidiaries

China

Hilscher Systemautomation (Shanghai) Co. Ltd.
200010 Shanghai
Phone: +86 (0) 21-6355-5161
E-Mail: info@hilscher.cn

Support

Phone: +86 (0) 21-6355-5161
E-Mail: cn.support@hilscher.com

France

Hilscher France S.a.r.l.
69500 Bron
Phone: +33 (0) 4 72 37 98 40
E-Mail: info@hilscher.fr

Support

Phone: +33 (0) 4 72 37 98 40
E-Mail: fr.support@hilscher.com

India

Hilscher India Pvt. Ltd.
New Delhi - 110 025
Phone: +91 11 40515640
E-Mail: info@hilscher.in

Italy

Hilscher Italia srl
20090 Vimodrone (MI)
Phone: +39 02 25007068
E-Mail: info@hilscher.it

Support

Phone: +39 02 25007068
E-Mail: it.support@hilscher.com

Japan

Hilscher Japan KK
Tokyo, 160-0022
Phone: +81 (0) 3-5362-0521
E-Mail: info@hilscher.jp

Support

Phone: +81 (0) 3-5362-0521
E-Mail: jp.support@hilscher.com

Korea

Hilscher Korea Inc.
Suwon, 443-810
Phone: +82-31-204-6190
E-Mail: info@hilscher.kr

Switzerland

Hilscher Swiss GmbH
4500 Solothurn
Phone: +41 (0) 32 623 6633
E-Mail: info@hilscher.ch

Support

Phone: +49 (0) 6190 9907-99
E-Mail: ch.support@hilscher.com

USA

Hilscher North America, Inc.
Lisle, IL 60532
Phone: +1 630-505-5301
E-Mail: info@hilscher.us

Support

Phone: +1 630-505-5301
E-Mail: us.support@hilscher.com